

U12 - UVC Tube Light

Ultraviolet Sterilisation/Disinfection

TECHNICAL DETAILS

Model No.
 U12 - 40W - 01/02
 U12 - 60W - 01/02
 U12 - 80W - 01/02

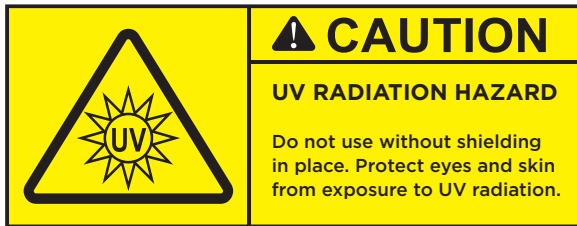

PRODUCT DETAIL

This product features dual motion sensor technology with PIR and microwave detection. These automatically deactivate the lamp when movement is detected near the illumination area. This helps to prevent unwanted exposure to UVC radiation. In the event of a fault in the motion sensors, the lamp will automatically turn off. A range of mains connection options are available including double-insulated cables and metal hoses.

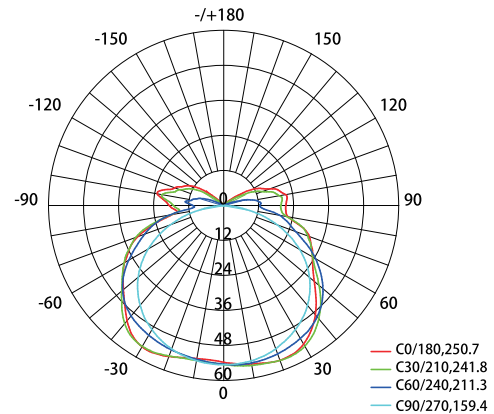

AVERAGE BEAM ANGLE (50%): 216 DEG.

The UVC light is protected by a metal grille, which protects the lamp tubes from damage.

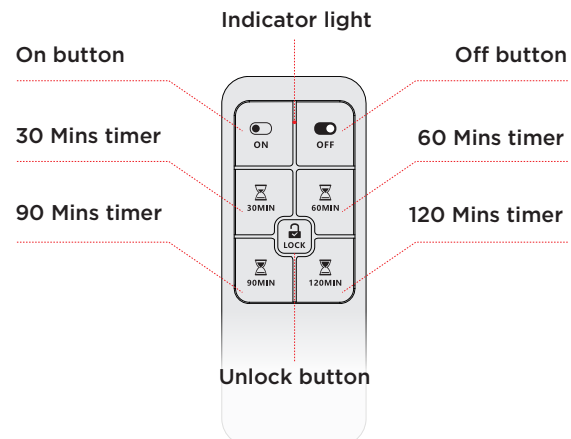
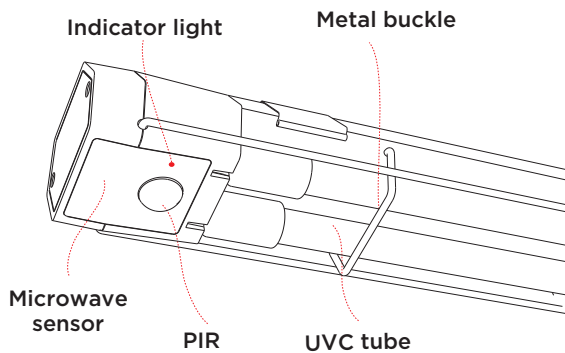

Remote Control Operation Instructions

Manual and Automatic Modes: Select the desired mode using the switch located behind the battery. Choose the desired mode before using the light.

Manual Mode: If the light is turned off manually or after detecting movement, it will not reactivate until the ON button is pressed.

Automatic Mode: If the light is off, it will reactivate if no movement is detected for 2 minutes.

Activating a Disinfection Cycle: To begin using the lamp, press the LOCK button, then choose the desired disinfection cycle. An alert will sound for 12 seconds, after which the lamp will begin operation.

Disinfection Cycle options: 30/60/90/120 minutes for timed cycles, ON for indefinite cycle. Cancel the time setting by pressing the OFF button.

Safety Features

Alert Signal: Before beginning a disinfection cycle an alert tone will sound for 12 seconds, and the indicator light will flash. People and animals should leave the illumination area to avoid exposure to UVC light.

Safety Sensors: The light features 3 PIR sensors and a microwave detector, which will activate when the light is in use. If any motion is detected near the illumination area, the light will automatically deactivate.

Each remote control is intended to work with one light. In cases where a remote control needs to be replaced, it is necessary to sync the new control with the light. To do so, turn the light on. Then, within 5 seconds, press the 120MIN button on the controller.

The remote control is shipped with tape across the battery contacts. Make sure to remove this before operation. If the remote is operating correctly, the LED will flash when any button is pressed. Until the LOCK button is pressed, the remote will be inactive. Make sure to press this button before using the remote.

U12 - UVC Tube Light

TECHNICAL SPECIFICATION

Operating temperature: -10- + 35°C
 Operating environment humidity: <80%
 Storage temperature: -20- + 60°C
 Storage environment: Humidity <80%, no corrosive air
 Sensor detection range: 360 degrees
 Sensor detection distance: 0 - 5 Metres
 Sensor type: 1 Microwave + 1 PIR Sensor
 Remote control distance: 10 Metres

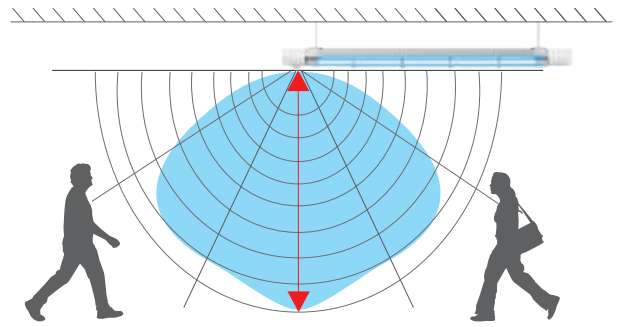

**Sensor detection distance:
5 Metres**

Principles and Sterilisation Factors

Sterilisation factor: Ultraviolet 253.7nm
 Principle: Use C- band ultraviolet light emitted by the UVC lamp to destroy bacteria and DNA of bacteria.

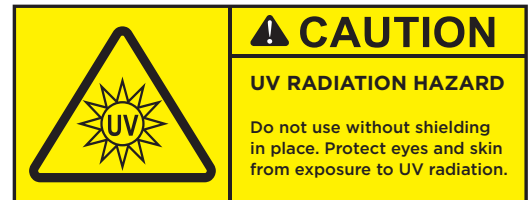

INSTALLATION

- * Avoid installing the lamp in direct air flow such as near fans, furnaces, or air outlets.
- * Ensure the motion sensors are not blocked and have a clear view of the illumination area.
- * The microwave motion sensor is tuned to pick up sudden movements, and may be triggered by heavy rain or by vibration of the sensor.
- * Lights should be installed at least 1 metre apart in order to avoid motion sensor interference.
- * Multiple lights may be controlled by a single remote, which is able to work through walls.
- * To sterilise the surface of objects, ensure that the lamp is positioned no further than 1.2 metres away. The closer the lamp is to the surface, the more effective sterilisation will be.

USAGE

- * If the lamp is to be used for air sterilisation, ensure that all doors and windows are closed.
- * The lamp should not be used at temperatures below -10 degrees Celsius, or higher than 35 degrees Celsius

TROUBLE SHOOTING

1	No “beep” or indicator light when the product is turned on.	1) Confirm connections to mains power. 2) Confirm the remote control is fitted with batteries and that they are positioned correctly.
2	Either the indicator light or the audible “beep” is not activated when the product is turned on.	1) Return the product for repair.
3	UVC lamp does not turn on	1) Confirm that the UVC unit is turned on. 2) Test the remote control with another unit, if possible. 3) Replace the tube. 4) Return to repair.
4	Remote does not work	1) Confirm that the UVC unit is turned on. 2) Press the “Lock” control, then activate the desired cycle length. 3) Replace remote control batteries.
5	Remote sensors deactivate the unit even when no movement is nearby.	1) Check that the motion sensors are unobstructed. 2) Ensure that the motion sensors are not affected by interference from air, water or vibration (as detailed above). 3) Test that the ambient air temperature does not exceed 35 degrees Celsius. 4) Return for repair.

U12 - UVC Tube Light

SUGGESTED AREA AND TIME

Model	Influenza ($\mu\text{W.S/cm}^2$)	Disinfection time/area for (1 Mtr distance to lamp)	Disinfection time/area for (1.5 Mtr distance to lamp)	Disinfection time/area for (2 Mtr distance to lamp)	Disinfection time/area for (2.5 Mtr distance to lamp)	Disinfection time/area for (3 Mtr distance to lamp)	Disinfection time/area for (3.5 Mtr distance to lamp)
U12 - 40W	6600	0.869 min (3.55 m ²)	1.958 min (7.23 m ²)	3.454 min (12.19 m ²)	6.336 min (18.43 m ²)	11.066 min (25.95 m ²)	20.284 min (34.74 m ²)
U12 - 60W		0.429 min (4.06 m ²)	1.001 min (7.98 m ²)	1.826 min (13.19 m ²)	3.146 min (19.67 m ²)	5.016 min (27.43 m ²)	7.59 min (36.47 m ²)
U12 - 80W		0.363 min (4.57 m ²)	0.836 min (8.74 m ²)	1.474 min (14.18 m ²)	2.453 min (20.91 m ²)	3.762 min (28.92 m ²)	5.841 min (38.2 m ²)

INSTALLATION DIAGRAM

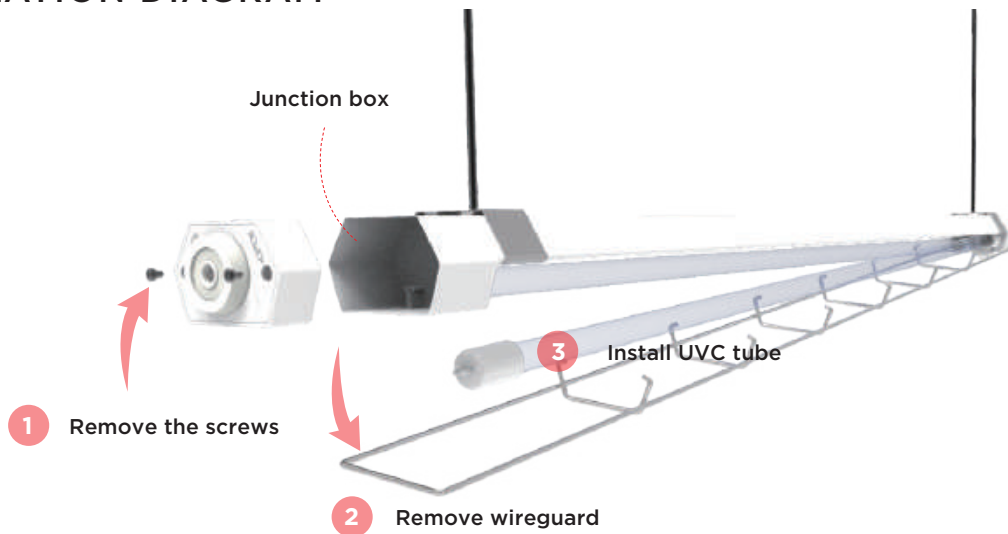

PLEASE NOTE:

Make sure the input voltage is within the range of the lamp.

SAFETY AND MAINTENANCE

This unit must only be serviced by professional technicians

- * UV light is for disinfection purposes only, not for illumination.
- * UVC radiation is not safe for disinfecting organic tissue. Do not use it to sterilise the surface of a human or animal body.
- * UVC radiation harms organic tissue, and is damaging to both humans and animals. Do not expose skin, and protect vulnerable areas such as eyes, mouth and any open wounds.
- * Severe effects of UVC radiation can include headaches, dizziness, increased body temperature, irritated eyes and decreased vision, as well as irritation, itching and swelling of the skin. Seek medical attention if any of these symptoms are experienced.
- * Warning: UVC radiation will affect any non-resistant objects in the illumination area. Paintings, plants, utensils and any other objects that are sensitive to UV radiation should be removed or covered. Non-UV resistant plastic can become brittle after long exposure to ultraviolet radiation.
- * To avoid accidentally reactivating the light, with the risk of unwanted exposure to UVC radiation, the lamp should be removed and stored if possible, along with the remote control.
- * Keep the lamp clean and free of dust or oil. For best results, use a damp cloth to wipe, then dry it thoroughly before activating the unit. Do not rinse the lamp using liquids, this product is not waterproof.
- * Do not use near flammable or explosive substances.

UV TUBE BREAKAGES

If the lamp tube breaks, the area must be thoroughly ventilated. UV lamp tubes contain mercury, which requires specialist cleaning equipment and disposal. Wear protective clothing, and do not use a standard vacuum cleaner. After disposing of a broken lamp tube, personnel must remove protective clothing and thoroughly clean their hands before touching their skin.

U12 - UVC Tube Light

WIRING INSTRUCTIONS

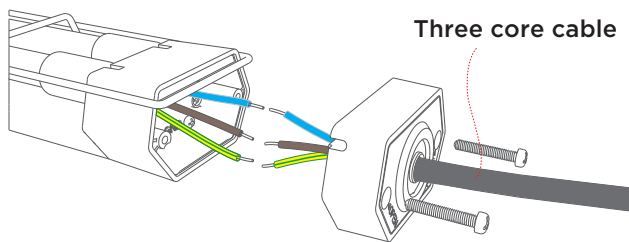

Schematic diagram of cable installation

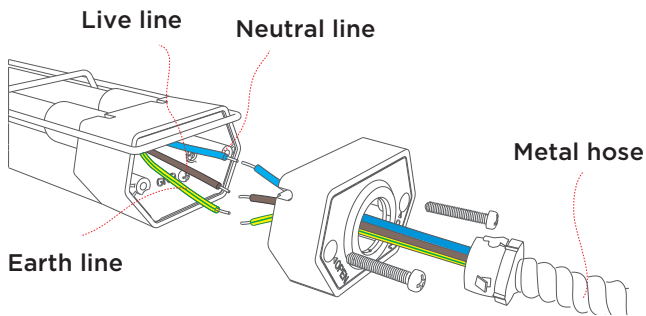

Wiring diagram of metal hose



PLEASE NOTE:

- 1) Make sure the input voltage is within the range of the lamp.
- 2) Please remove all packing material and protective foam.

WALL MOUNT AND HANGING INSTRUCTIONS

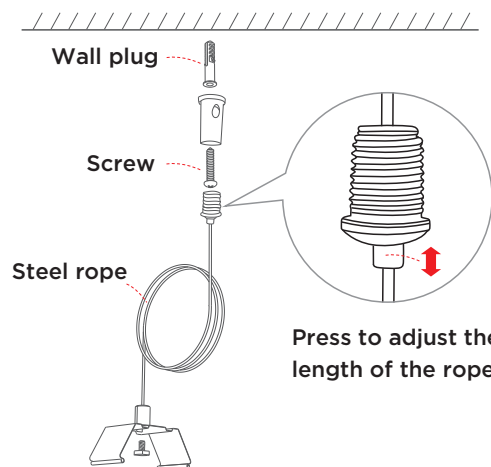
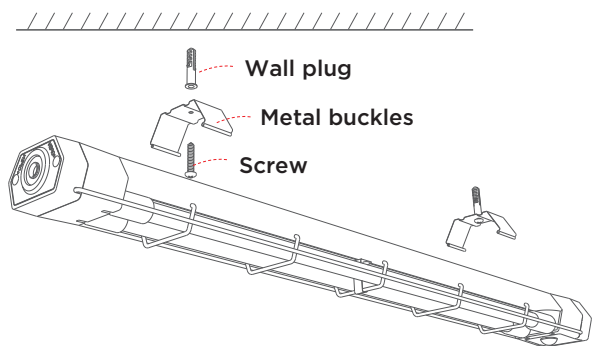

INSTALLATION OPTIONS

CEILING MOUNT



Installation height 2.3 to 5 metres from ground level

HANGING

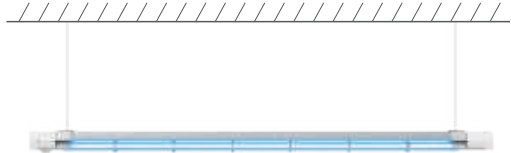

Installation height 2.3 to 5 metres from ground level

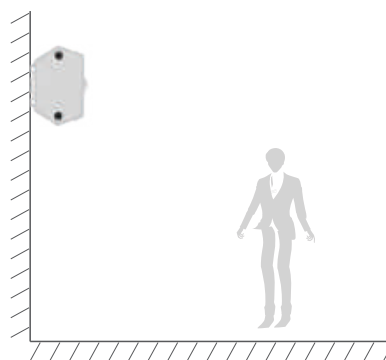

WALL MOUNT

WARRANTY INFORMATION

The manufacturer warranty covers defects in components, technology and the manufacturing process for the first year after purchase. The warranty service has the following exceptions:

- * If the product has passed its effective service life
- * Damage caused by improper use or installation.
- * Damage caused in transport or in other accidents.
- * Aging and wearing of components that does not affect the standard use of the product.
- * In cases of force majeure

WHI Safeguard Limited
Meryll House, 57 Worcester Road
Bromsgrove, B61 7DN, England.
T. 44 (0) 1753 325 101
E. info@whisafeguard.com
WHI Safeguard is a registered trademark

